

USE and MAINTENANCE INSTRUCTION MANUAL

- **DDP 120 B**

DDP 120 B.TE (Aluminium)
DDP 120 BN.TE (Stainless Steel)
DDP 120 B WB.TE (Anodized Aluminium)

- **DPS 120 C**

DPS 120 C.TE (Aluminium)
DPS 120 CN.TE (Stainless Steel)
DPS 120 C WB.TE (Anodized Aluminium)

- **DDP 90 E**

DDP 90 F.TE (Aluminium)
DDP 90 FN.TE (Stainless Steel)
DDP 90 F WB.TE (Anodized Aluminium)

- **DPS 90 G**

DPS 90 G.TE (Aluminium)
DPS 90 GN.TE (Stainless Steel)
DPS 90 G WB.TE (Anodized Aluminium)

DOUBLE DIAPHRAGM P U M P S LOW PRESSURE



	USE OF THE MANUAL WARRANTY	3
1.	SAFETY WARNING	4
2.	TRANSPORT AND HANDLING	6
2.1	TRANSPORT	6
2.2	TRANSPORT WITH CARDBOARD PACKAGING.....	6
2.3	HANDLING	6
2.4	TEMPORARY STORAGE	7
2.5	CHECK ON THE PURCHASED PRODUCT	7
3.	PRODUCT IDENTIFICATION	8
3.1	PLATE DATA	8
3.2	COMPLIANCE TO THE STANDARDS	8
4.	THECNICAL SPECIFICATIONS	9
4.1	DPS VERSIONS	10
4.2	DPS_MODELS DIMENSIONS & WEIGHTS	11
4.3	SAFETY SYSTEMS	12
4.4	SAFETY PICTOGRAMS.....	12
4.5	WORKABLE PRODUCTS	13
5.	PUMP OPERATION	14
5.1	OPERATION DESCRIPTION	14
6.	INSTALLATION AND STARTING	15
6.1	CONDITIONS FOR INSTALLATION	15
6.2	INSTALLATION	15
6.3	INSTALLATIONS OF DPS MODELS	16
7.	USE	19
7.1	USE	19
7.2	SAFETY RULES DURING USE	19
7.3	CLOTHES	19
7.4	PREWASH	19
7.5	STARTING	20
7.6	DAILY INTERRUPTIONS	20
7.7	WRONG AND DANGEROUS USES	21
7.8	PRESSURE RELEASE PROCESS	22
8.	MAINTENANCE AND INSPECTIONS	23
8.1	GENERAL NOTES	23
8.2	SAFETY RULES DURING MAINTENANCE	23
8.3	RECOMMENDED SCHEDULED OPERATIONS	23
8.4	DIAPHRAGM PUMP DISASSEMBLY FROM IT BASE SUPPORT	23
8.5	LID, CONNECTOR & AIR OPERATING VALVE DISASSEMBLY	24
8.6	DIAPHRAGM SET DISASSEMBLY	24
8.7	DIAPHRAGM SET REASSEMBLY	24
8.8	INTAKE AND EXHAUST VALVE DISASSEMBLY	25
8.9	INTAKE AND EXHAUST VALVE REASSEMBLY	25
9.	PAINT PRESSURE REGULATOR	26
9.1	TECHNICAL SPECIFICATION PAINT PRESSURE REGULATOR	26
9.2	PAINT REGULATOR MAINTENANCE, DISASSEMBLY & ASSEMBLY (9.3 - 9.4)	26
9.5	SET UP OF 2-WAY CONNECTION KIT (OPTIONAL)	27
9.6	PAINT FILTER MAINTENANCE	27
10.	SPARE PARTS LIST	28
10.1	DPS DIAPHRAGM PUMP SET	28
10.2	DDP DIAPHRAGM MAIN BODY SPARE PARTS	28
10.3	PAINT PRESSURE REGULATOR SPARE PARTS	30
10.4	2-WAY CONNECTION KIT SPARE PARTS	30
10.5	AIR REGULATOR SET	31
10.6	PAINT FILTER SET	31
10.7	ACCESSORIES	31
10.8	SUCTION HOSE, SUCTION PIPE & DRAIN HOSE	31
11.	TROUBLE SHOOTING	33
11.1	DIAPHRAGM PUMP TROUBLE SHOOTING	33
11.2	PAINT PRESSURE REGULATOR TROUBLE SHOOTING	35
12	EQUIPMENT STORAGE	35
12.1	DISMANTLING	35

**USE OF THE
MANUAL**

This use and maintenance manual is an integral part of the equipment and must be easily available to the staff in charge of its use and maintenance. The user and the personnel in charge of maintenance must be aware of the contents of this manual.

Read the manual carefully before starting ANY ACTIVITY involving the equipment, including its handling. For easier references the instruction manual has been divided into the following sections:

WARNING

THE ORIGINAL CONFIGURATION OF THE EQUIPMENT MUST NOT BE CHANGED.

Upon receiving the equipment make sure that:

- The supply corresponds to the order specifications.
- In case of non-compliance, inform our Technical Service immediately.

**WARNING**

ALL RIGHTS ARE RESERVED. THE REPRODUCTION OF ANY PART OF THIS MANUAL, IN ANY FORM, IS STRICTLY FORBIDDEN WITHOUT PRIOR WRITTEN AUTHORIZATION OF THE MANUFACTURING COMPANY.

WARRANTY

All the products of ANEST IWATA have a one-year warranty from invoice date, unless otherwise stated in writing. The warranty covers all manufacturing faults and material defects.

Any spare part replacement or repair operation is covered only if it is carried out by our technicians at our servicing shops.

The warranty covers no intervention of our technicians during installation or dismantling operations. If for practical purposes one of our technicians is sent to the premises, the time plus extra for travelling and expenses will be invoiced at current prices. Our warranty does not cover direct or indirect damage to people or property caused by our equipment. It covers no repair operations carried out by the customer or by a third party, either.

THE WARRANTY DOES NOT COVER:

- Damage or breakdown caused by improper use or assembly.
- Damage or breakdown caused by the use of spare parts different from the original or recommended ones.
- Damage or breakdown caused by bad preservation.
- Components subject to wear (described in the spare parts list).

WARRANTY FOR FEITURE:

- In case of delayed payment or other breaches of contract.
- Whenever changes or repairs are carried out on our equipment without our prior authorisation.
- Whenever the serial number is damaged or removed.
- When the damage is caused by improper use or functioning, or if the equipment falls, is bumped or by other causes not due to normal working conditions.
- Whenever the unit is disassembled, tampered with or repaired without the authorisation of **ANEST IWATA**.

All repair interventions carried out under warranty do not interrupt its duration.

All disputes will be settled in the court of justice of Turin.

- Be sure to read and understand this instruction manual. The operator shall be fully conversant with the requirements stated within this instruction manual including important warnings, cautions and operations.
- Wrong operation (mishandling) can cause serious bodily injury, death, fire or explosion.

SAFETY FACTOR

- Pay special attention to items which are shown by the below marks and symbols.

WEAR PROTECTIVE GEAR



During painting, be sure to wear protective gear such as glasses, mask or gloves to avoid serious injury caused by paints or solvents which might enter your eyes or you might inhale.

BE CAREFUL ABOUT VENTILATION



Use it in a well-ventilated area. Painting or cleaning in a narrow area with insufficient ventilation can cause organic solvent intoxication or explosion due to sprayed mist of paint or solvent which catches fire.

If you feel any abnormality during operation, consult a medical doctor immediately.

CONTACT IS FORBIDDEN



If paint leaks, never try to stop it by hand. In that case please proceed as follows:

1. Follow the instructions about release pressure procedure, provided in section 7.8.
2. Check the leakage causes.
3. Replace or repair the faulty component.

BE CAREFUL ABOUT BODILY INJURY



Paint can enter human body directly through eyes, mouth or skin. It is very dangerous. If you feel any abnormality or receive any injury, consult a medical doctor immediately.

LIMIT OF FLUID TO BE USED

Do not use it for food products.

KEEP AWAY FROM ORIGINS OF EXPLOSIONS OR FIRES



Never use near sparks or open fire.

Especially the following will cause fire

- Open flames such as cigarettes, pipes.
- Electric goods such as stoves, lamps or heaters.

CONNECT GROUNDING



Securely ground pump, spray gun, workpieces and containers containing paint or solvent.
Be sure to use ground wire set supplied with pump set.
Connect it to ground to have continuous grounding.

Insufficient grounding will cause explosion or fire if exposed to a spark of electricity.

WARNING!

BE CAREFUL ABOUT EXPLOSION



Be sure to use paint pump at less than max. fluid working pressure (section 4.).
Use at more than max. fluid operating pressure can cause explosion of pump resulting in great danger.

Never bend hose with a radius of less than 50mm. Never put heavy things on it (in order not to damage the hose). If done, hose can explode causing great danger.

Securely connect hose to avoid leak and looseness. If hose is disconnected during operation, hazardous hose movement and paint ejection will cause severe bodily injury.

Never use cracked, damaged, bent, crushed or distorted hose. Leakages from such a hose can cause great danger during operation.

IMPORTANT



Never alter the equipment
When you replace parts, be sure to use our genuine parts. If not done, it can cause insufficient performance or failure.

Install or keep pump free from rain or splashes. If not done, it can cause pump failure

Install pump on a horizontal surface

Install pump free of paint mist. Attached paint mist etc., can cause pump failure

Use clean air filtered through dryer and filter (finer than 50 microns). If not done, it can cause pump failure.

*** We shall not be responsible for any injury or damage caused by disregard of warnings, cautions or instructions.**

2.1 TRANSPORT

To transport the equipment only the systems described below can be used. In any case make sure that the transport and lifting device can bear the weight of the equipment with its packaging.



WARNING
ALWAYS KEEP THE PACKAGING IN VERTICAL POSITION.



WARNING
IT IS ADVISABLE THAT THE STAFF IN CHARGE OF HANDLING THE EQUIPMENT WEAR PROTECTIVE GLOVES AND SAFETY SHOES.



WARNING
WHILE LIFTING OR HANDLING THE EQUIPMENT OR ANY OF ITS COMPONENTS CLEAR THE WORKING AREA. LEAVE ALSO A SUFFICIENT SAFETY AREA AROUND THE EQUIPMENT TO AVOID DAMAGING PEOPLE OR OBJECTS WHICH COULD BE THERE.

2.2 TRANSPORT WITH CARDBOARD PACKAGING

The equipment is put inside a cardboard packaging and wrapped with some shockproof material.

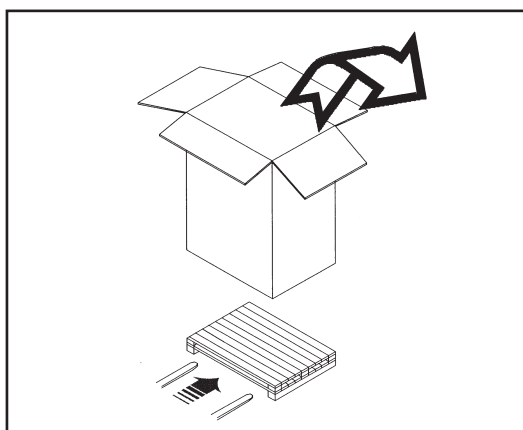

2.3 HANDLING

To handle the cardboard packaging use a trolley.



WARNING
FOLLOW THE INSTRUCTIONS ON THE PACKAGING BEFORE HANDLING AND OPENING IT.

HANDLING BY MEANS OF HANDLE

HANDLING BY MEANS OF TROLLEY

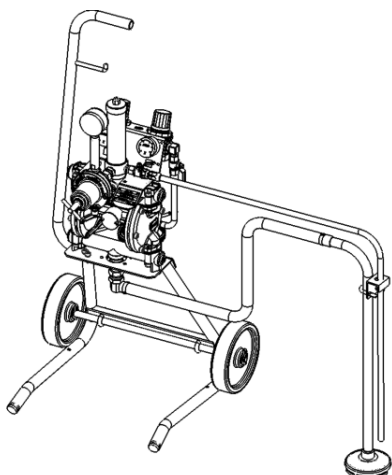

2.4 TEMPORARY STORAGE

During transport and storage make sure the temperatures between 0 and 40° C are not exceeded.

In case of storage, make sure the equipment is not put in places with an excessive humidity.

2.5 CHECK ON THE PURCHASED PRODUCT

When you receive and before using the pump, make sure it has not been damaged during transport or storage. Also check that all standard components are inside the packaging.

	STAND	CART	ALL MODEL	TANK	WALL
PR-5BL			1		
Drain hose set			1		
*Cart set	-	1		-	-
Supply lid	-	-		1	-
Hose band	3	3		-	3
Suction hose set with filter	1	1		-	1
Dip tube with filter	-	-		1	-
**Gravity hopper set	-	1		-	-

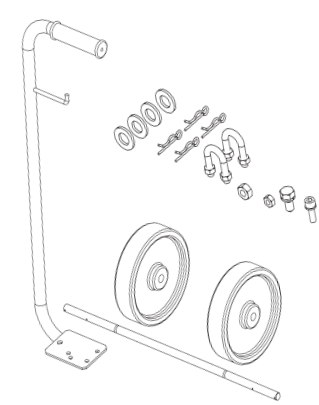
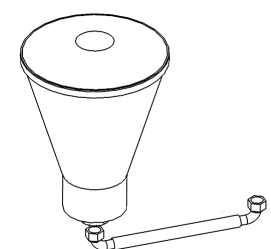
*CART SET		
AXLE	1	
“U” BOLT _ HEX. NUT	2 + 4	
SNAP PIN	4	
WASHERS	4	
SOLID TIRES	2	
HANDLE	1	
HEX. NUT (M8)	1	
BOLT WITH HEX. HOLE (M8)	1	
HEX. NUT (M6)	1	
BOLT WITH HEX. HOLE (M6)	1	
**HOPPER SET		
HOPPER	1	
“U” HOSE	1	

3.1 PLATE DATA

The manufacturer's identification plate is applied on the diaphragm pump (see picture below).

It must not be removed at all, even if the equipment is resold. For any communication with the manufacturer always mention the serial number written on the plate itself.

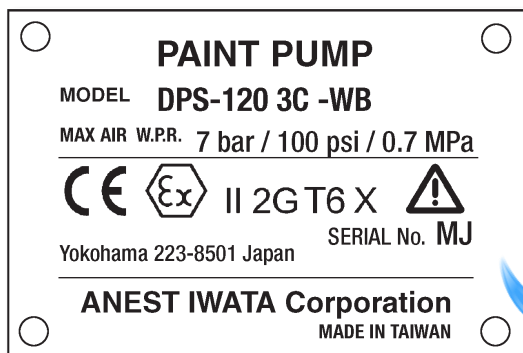

3.2 COMPLIANCE TO THE STANDARDS



All the units are conceived in compliance with the applicable Essential Safety Requirements of the Machinery Directive 2006/42/EC.

The units are also designed and manufactured in compliance with the Essential Safety Requirements (ESR) of Annex II of Directive "ATEX" 2014/34/EU and they comply with the following classification:





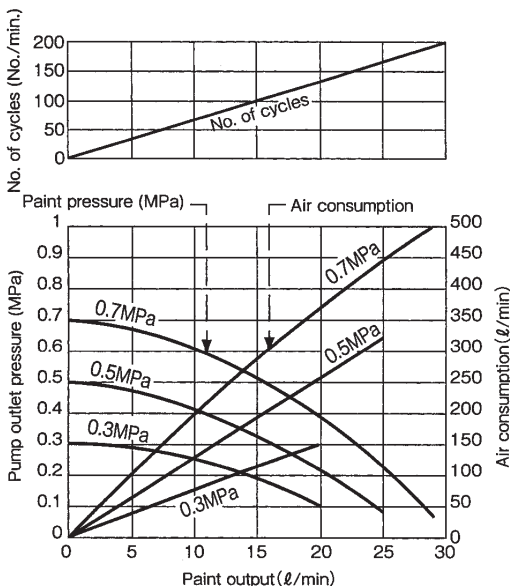
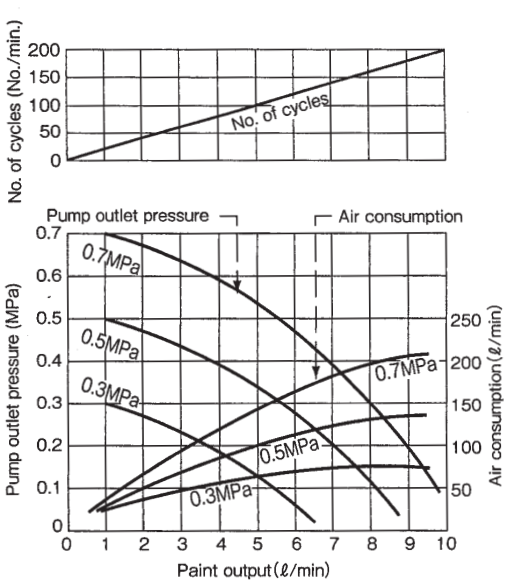

- Equipment group : II
- Category: Gas 2G (Suitable for use in zones 1 and 2)
- Max. surface temperature: temperature class T6
- X marking : Any static electricity discharge from the pump is to be diverted to the ground through the grounding wire which is included in this product.

4. TECHNICAL SPECIFICATIONS

Pump Unit	DDP-120B.TE			DDP-90F:TE		
	 					
PUMP TYPE	DDP-120B	DDP-120BN	DDP-120B-WB	DDP-90F	DDP-90FN	DDP-90F-WB
PUMP VERSION	DPS-120C.TE			DPS-90G.TE		
Paint Passages	Aluminum	Stainless Steel	Anodized Aluminum	Aluminum	Stainless Steel	Anodized Aluminum
Air Working Pressure Range	1.5~7 bar 22~100 psi					
Max. Fluid Working Pressure	7 bar (100 psi)					
Air Inlet	G 1/4"					
Fluid Outlet	G 3/8"					
Fluid Inlet	G 1/2"					
Paint Delivery at 30 cyc/min	4.5 lt./min			1.5 lt./min		
Paint Delivery at 200 cyc/min	30lt./min			10lt./min		
Paint viscosity	85sec/Ford#4					
Working Temperature	5~40°C					
Compressor (required power)	0.4~1.5 kW			0.4~0.75 kW		
Noise Level	70 dB(A)			68 dB(A)		
Performance Curve	 <p>* 0.3/0.5/0.7 MPa in graph shows air pressure * Test by turpentine</p>			 <p>* 0.3/0.5/0.7 MPa in graph shows air pressure * Test by turpentine</p>		

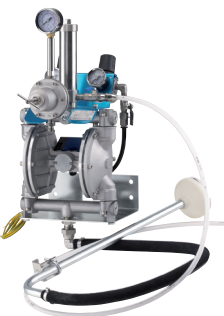
4.1 DPS_VERSIONS

STAND TYPE	DPS 120-1C.TE/CN.TE/C-WB.TE	DPS 90-1G.TE/GN.TE/G-WB.TE
	<p>DDP version mounted on stand, with paint regulator, 2 air regulators (for pump and gun), paint filter unit, dip tube with filter, fluid recirculation, 1 overpressure valve, ball valve with exhaust hole.</p> <ul style="list-style-type: none"> • PR-5BL paint regulator for DPS 120-1C.TE and DPS 90-1G.TE • PR-5BLN paint regulator for DPS 120-1CN.TE and DPS 90-1GN.TE • PR-5BL WB paint regulator for DPS 120-1C-WB.TE and DPS 90-1G-WB.TE 	
TANK MOUNT TYPE	DPS 120-2C.TE/CN.TE/C-WB.TE	DPS 90-2G.TE/GN.TE/G-WB.TE
	<p>DDP version mounted on Tank mount lid (without tank) with paint regulator, 2 air regulators (for pump and gun), paint filter unit, dip pipe with filter (for 20L tank), fluid recirculation, overpressure valve, ball valve with exhaust hole.</p> <ul style="list-style-type: none"> • PR-5BL paint regulator for DPS 120-2C.TE and DPS 90-2G.TE • PR-5BLN paint regulator for DPS 120-2CN.TE and DPS 90-2GN.TE • PR-5BL WB paint regulator for DPS 120-2C-WB.TE and DPS 90-2G-WB.TE 	
CART TYPE	DPS 120-3C.TE/CN.TE/C-WB.TE	DPS 90-3G.TE/GN.TE/G-WB.TE
	<p>DDP version mounted on wheel cart with paint regulator, 2 air regulators (for pump and gun), paint filter unit, dip tube with filter, fluid recirculation, 1 overpressure valve, ball valve with exhaust hole.</p> <ul style="list-style-type: none"> • PR-5BL paint regulator for DPS 120-3C.TE and DPS 90-3G.TE • PR-5BLN paint regulator for DPS 120-3CN.TE and DPS 90-3GN.TE • PR-5BL WB paint regulator for DPS 120-3C-WB.TE and DPS 90-3G-WB.TE 	
WALL MOUNT TYPE	DPS 120-4C.TE/CN.TE/C-WB.TE	DPS 90-4G.TE/GN.TE/G-WB.TE
	<p>DDP version mounted on wall mounting bracket with paint regulator, 2 air regulators (for pump and gun), paint filter unit, dip tube with filter, fluid recirculation, 1 overpressure valve, ball valve with exhaust hole.</p> <ul style="list-style-type: none"> • PR-5BL paint regulator for DPS 120-4C.TE and DPS 90-4G.TE • PR-5BLN paint regulator for DPS 120-4CN.TE and DPS 90-4GN.TE • PR-5BL WB paint regulator for DPS 120-4C-WB.TE and DPS 90-4G-WB.TE 	
CART TYPE w/ HOPPER	DPS 120-36C.TE/CN.TE/C-WB.TE	DPS 90-36G.TE/GN.TE/G-WB.TE
	<p>DDP version mounted on wheel cart with paint regulators, 2 air regulators (for pump and gun), paint filter unit, plastic hopper (6 lt. with 50 mesh filter), fluid recirculation, 1 overpressure valve, ball valve with exhaust hole.</p> <ul style="list-style-type: none"> • PR-5BL paint regulator for DPS 120-36C.TE and DPS 90-36G.TE • PR-5BLN paint regulator for DPS 120-36CN.TE and DPS 90-36GN.TE • PR-5BL WB paint regulator for DPS 120-36C-WB.TE and DPS 90-36G-WB.TE 	

4.2 DPS VERSIONS_ DIMENSIONS AND WEIGHT

UNIT ASSEMBLY		Dimensions (mm)	Weight (kg)		Dimensions (mm)	Weight (kg)
STAND TYPE	DPS-120C	409x358x806	10.5 (C)	DPS-90G	409x358x764	9.6 (G)
			13.9 (CN)			11.7 (GN)
			10.5 (C-WB)			9.6 (G-WB)
TANK MOUNT TYPE		357x312x798	9.6 (C)		357x312x756	8.7 (G)
			12.1 (CN)			10.8 (GN)
		9.6 (C-WB)		8.7 (G-WB)		
CART TYPE		437x452x868	13.0 (C)		437x452x868	12.1 (G)
			15.5 (CN)			14.2 (GN)
			13.0 (C-WB)			12.1 (G-WB)
WALL MOUNT TYPE		363x214x534	9.5 (C)		363x214x492	8.6 (G)
			12.0 (CN)			10.7 (GN)
			9.5 (C-WB)			8.6 (G-WB)
CART TYPE w/ HOPPER 6 lt.		526x528x868	13.0 (C)		526x528x868	12.1 (G)
			15.5 (CN)			14.2 (GN)
			13.0 (C-WB)			12.1 (G-WB)

4.3 SAFETY SYSTEMS

Several safety systems have been conceived during the diaphragm pump design and manufacture to safeguard the operator, as it prescribed by all applicable safety regulations.

SAFETY VALVE

A 7 bar calibrated safety valve is installed to ensure the pump working pressure does not exceed the limits inside the feeding circuit.

If the calibration pressure is exceeded, the valve opens by releasing the excess of air.

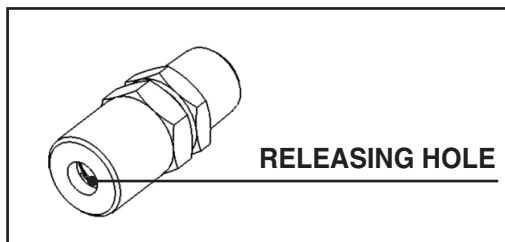

WARNING

DO NOT DISASSEMBLE THE SAFETY VALVE. ANY TAMPERING WITH COULD BE DANGEROUS FOR THE OPERATOR AND COMPROMISE THE EQUIPMENT GOOD WORKING.

EXHAUST VALVE

In case of anomalies during working, turn 90° the exhaust valve lever. In this way the air supply will be interrupted and the residual pressure inside the pump will be released.



ON



OFF

4.4 SAFETY PICTOGRAMS

Some pictograms can be found on the pump with the safety warnings to follow by anyone who is going to use it.



WARNING

THE MANUFACTURING COMPANY IS NOT TO BE HELD RESPONSIBLE FOR DAMAGE OR ACCIDENTS TO PEOPLE OR THINGS COMING FROM THE NON-COMPLIANCE WITH THE PRESCRIBED RULES. THE RESPONSIBILITY RESTS ENTIRELY WITH THE OPERATOR HIMSELF.

4.5 WORKABLE PRODUCTS

All ANEST IWATA DPS Diaphragm Pumps are conceived to paint ferrous material in general, wood and plastic.

Models DPS-120C.TE and DPS-90G.TE are designed for paints with a maximum viscosity of 85 sec/Ford #4 (100 sec/NK-2). We don't recommend the use of these models with water-based paints.

Models DPS-120CN.TE/C-WB.TE and DPS-90GN.TE/G-WB.TE are intended also for water-based paints.

To use the pump with special products ask for the manufacturer's approval. Moreover, the pump technical features will have to be adapted to the special product working.

The Company ANEST IWATA is not to be held responsible for any accident due to the pump use by an UNAUTHORIZED and non qualified staff using it for purposes that are different from the above mentioned ones.



WARNING

NEVER USE THE FOLLOWING HALOGENATED HYDROCARBON SOLVENTS :

- METHYL CHLORIDE, DICHLOROMETHANE, 1.2-DICHLOROETHANE, CARBON TETRACHLORIDE, TRICHLOROETHYLENE, 1.1.1-TRICHLOROETHANE WHICH CAN CAUSE CRACKS OR DISSOLUTION ON GUN BODY (ALUMINUM) BY CHEMICAL REACTIONS.
- VERY TOXIC PRODUCTS SUCH AS PETROL, KEROSENE COMBUSTIBLE GASES;
- ANY HERBICIDE OR PESTICIDE
- ANY RADIOACTIVE FLUID

**(Be sure that all fluids and solvents are compatible with gun parts.
We are ready to supply a material list used in the gun on request.)
Do not use with corrosive liquids (except for PH6-8)**

5.1 OPERATION DESCRIPTION

Based on a simple manufacture, the operation consists in two diaphragm movement, which are both fixed at the end of a rod, pressurizing and sending the paint.

The compressed air enters the air chamber from side A in picture 1. The diaphragm is moved to the left, by pushing the paint.

At the same time, the diaphragm on the opposite end (side B) moves to the left by sucking the paint.

When the rod is completely on the left, the double pneumatic valve reverses the operations.

The compressed air enters the air chamber from side B in picture 2. The diaphragm is moved to the right, by pushing the paint.

At the same time, the diaphragm on side A end sucks the paint.

The pump repeats the above-mentioned suction and delivery movements. The result is a steady and pulsation-free material flow.

The main feature is the action of two pneumatic valves: the first one is a power valve feeding the pump, and the other one a control valve always ensuring the movement.

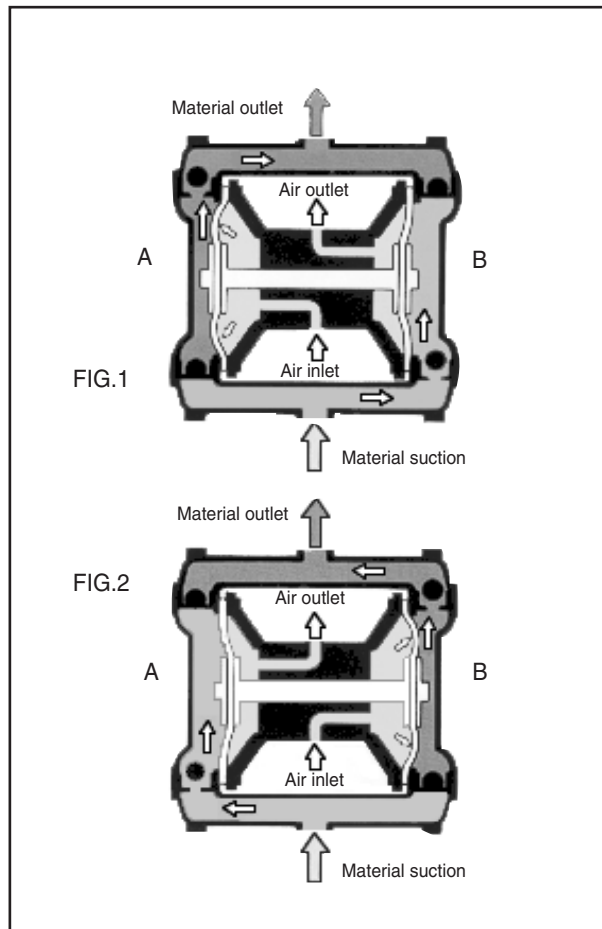

6.1 CONDITIONS FOR INSTALLATION



The installer must know the ATEX classification of the installation area, as well as the risks coming from a potentially explosive atmosphere, by paying attention to the explosion and fire risks so as to adopt the most suitable protections. All maintenance, assembly and disassembly operations must be carried out by a qualified staff outside the area at risk of explosion. Also check that the accessories comply with the essential safety requirements of the ATEX directives. Handle them with great care to avoid changing their features. Once installed, clean the unit.

The equipment must be installed by a specialized and authorized staff. In any case, follow the instructions below.



WARNING

IF PAINTING IS CARRIED OUT OUTSIDE THE SPRAY BOOTH, ALWAYS OPERATE IN A PLACE WITH A RIGHT VENTILATION TO AVOID CONCENTRATING INFLAMMABLE VAPOURS COMING FROM SOLVENTS OR PAINTS.

6.2 INSTALLATION

- Place the pump on a stable surface, to avoid movements during use.
- The distance between the pump and the paint (height of suction) must be as short as possible. However, it can vary according to viscosity and required delivery.
- Connect the air supply to the supply connection of the pump.
- The suction pipe must have an inside diameter of at least 1/2" or slightly higher.
- To install the pump use two M8x12 screws by means of the special holes on the lower adaptor. Do not fasten the pump with any other system.
- Connect the free end of the GROUND WIRE directly.



WARNING

THE FLUIDS USED AND THE REQUIREMENTS MUST BE IN COMPLIANCE WITH SECTION 4.5 (WORKABLE PRODUCTS) AND WITH SECTION 7.0 (USE).

WARNING

- CONSULT THE LOCAL CODE FOR DETAILED INSTRUCTIONS RELATIVE TO GROUND CONNECTIONS IN THE WORK AREA AND TO THE TYPE OF SYSTEM USED.
- THE GROUND WIRE (INCLUDED) MUST HAVE A MINIMUM SECTION EQUAL TO 1.5 mm².
- ONE END OF THE CABLE MUST BE EARTHEN WHILE THE OTHER MUST BE CONNECTED TO THE LATERAL LID OF THE DIAPHRAGM PUMP.



Fasten the pump to the ground by means of the bracket welded on the trailer or on the stand.

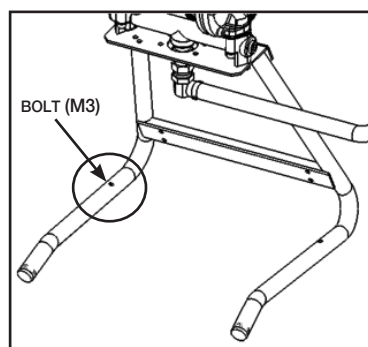

6.3 INSTALLATION OF DPS MODELS

1	A - STAND TYPE AND CART TYPE	COMMON
<ol style="list-style-type: none"> 1. Remove the dust proof caps (B,E,F,H,I on page 21) 2. Detach the pump assembly from the support by removing Hex. Bolts (M8). 3. Flip the stand and assemble the pump assy to the right position. 		<ol style="list-style-type: none"> 1. Connect the drain hose to the two-way valve for paint recirculation.

2	PAINT SUPPLY / SUCTION HOSE
<ol style="list-style-type: none"> 1. Connect the suction hose to the paint inlet joint (H page 21). 2. Fix the drain hose to the suction hose with band (3 spots wherever you want). 	

B - TANK MOUNTING TYPE		
<ol style="list-style-type: none"> 1. Remove the dust proof caps (B,E,F,H,I on page 21) 2. Assemble the supply lid in its seat, connect the drain hose to the two-way valve for paint recirculation.(as COMMON 1) 3. Connect the suction hose to the paint inlet joint. (Make sure the seal tape is taped around the suction hose) 		

C - CART TYPE

1. Assemble the following parts below in numerical order, and fix them to the stand.

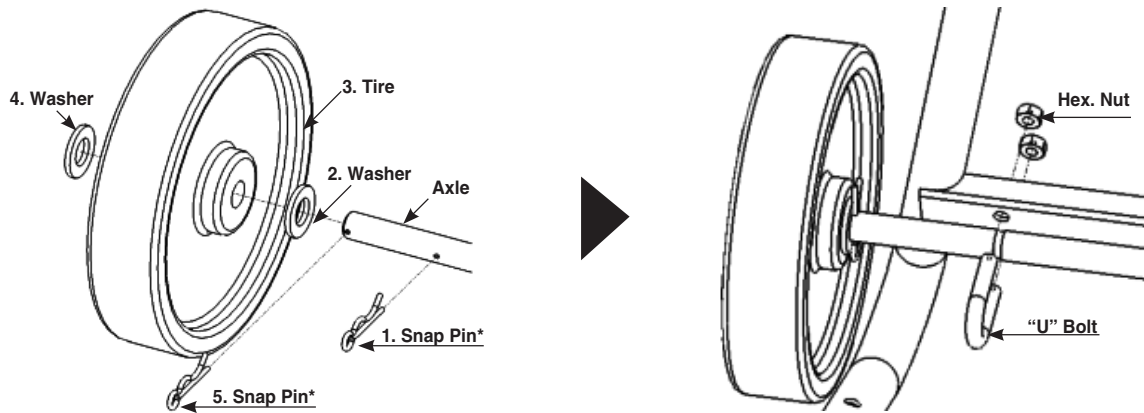

* Put the end of the pin into axle hole, and push it inside all the way by using hammer.

As is when is fitted.

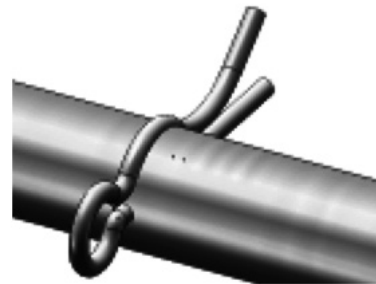

2. Unscrew from pump lower adaptor the fitting bolt (M8) and assemble the handle on stand by using hex. bolt (M8) and bolt with hex. hole (M6).

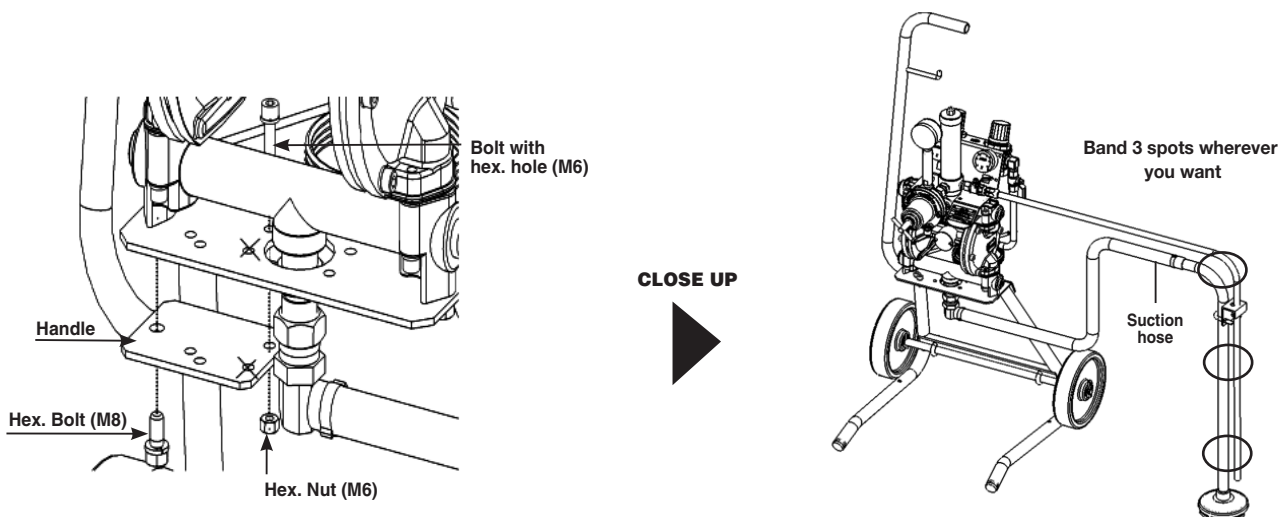

D - WALL MOUNTING TYPE

1. Remove the dust proof caps (B,E,F,H,I on page 21)
2. Detach the pump assembly from bracket by removing hex. Bolts (M8)
3. Flip the bracket and assemble the pump to the right position on bracket by using hex. Bolts (M8).
4. Connect the drain hose to the two-way valve for paint recirculation. (as COMMON 1)
5. Connect the suction hose to the paint inlet joint.

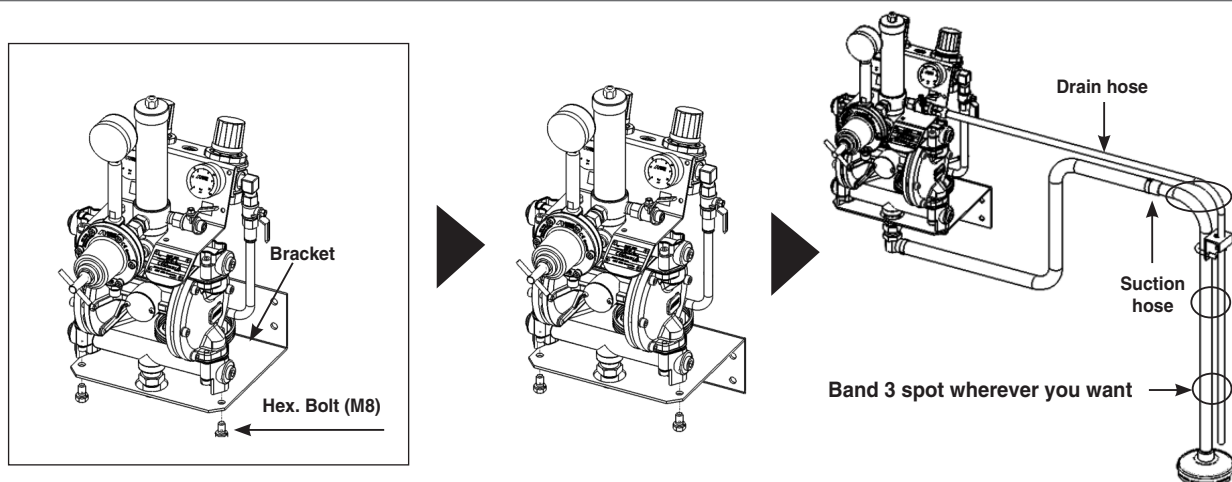

E - GRAVITY HOPPER TYPE (6 LT.)

1. Assemble the hopper set by means the “U” suction tube, to the paint inlet joint of the pump mounted on cart.
2. Connect the drain hose from two-way valve for paint recirculation to hopper lid set directly.

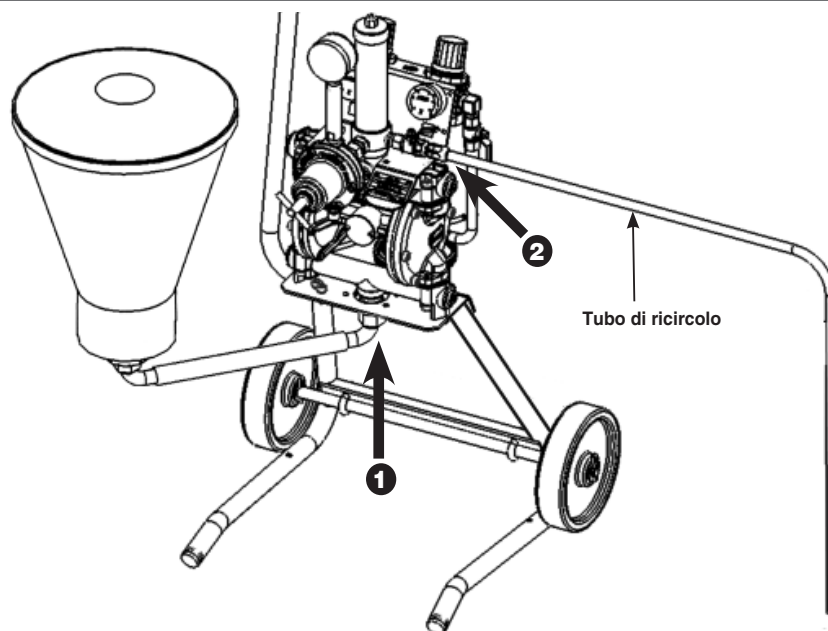

7.1 USE

This section describes the diaphragm pump use in compliance with the safety standards in force. Read this section carefully.

7.2 SAFETY RULES DURING USE

TO USE the diaphragm pump **COMPLY WITH** the safety precautions and rules described below.

The manufacturing company declines all responsibility if the operator does not comply with them. It is not to be held responsible for any carelessness during the pump use, either.

If the system is used improperly, it could be broken by causing serious damage.

Do not change the system; use only ANEST IWATA original spare parts.

Check the system daily: repair or replace immediately all worn or damaged parts.

Never exceed the maximum working pressure: 7 bar (100 psi)

IT IS FORBIDDEN to use the equipment for purposes that are different from the ones it is destined to which are described in the use and maintenance manual. If in doubt, apply to your ANEST IWATA reseller.

Use paints and solvents compatible with the system parts they come in touch with.

Refer to the paint and solvent features mentioned by the manufacturer.

Wear the protective clothes described in section 7.3

Comply with all the local standards on electric safety and fire risks.

7.3 CLOTHES

Wear some protective gloves and goggles, an oxygen mask and some ear protections during working. In any case, follow the references of the current regulations.

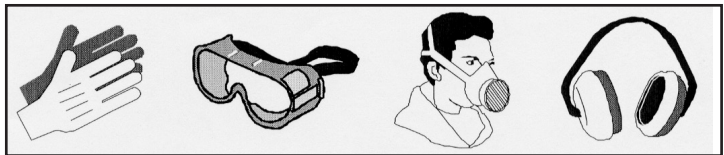

7.4 PREWASH

1. Make sure the pump is installed correctly (see section 6.3).
2. Soak the suction tube into the washing liquid, or fill the hopper or the tank according to the model used.
3. Put the ball valve in the right position.
4. Adjust the inlet pressure between 2.0 and 7 bar.
5. Open gradually the two-way valve for paint recirculation (B on page 21). The washing liquid will have to circulate through the dip tube recirculation pipe.
 - If the Tank mount model is used, the washing liquid will circulate through the paint handling system (JET STREAM).
 - In the Hopper model, recirculation pipe is directly connected to the hopper.
6. Close the two-way valve for paint recirculation and adjust the paint pressure by means of Paint Regulator (Recommended pressure for washing 3.0 bar)
7. Press the gun trigger (or supply the automatic gun opening control with some air), without spraying air and let the washing fluid circulate for some minutes.
8. Make sure the washing has been done and then discharge the pump residual liquid and stop it.

**WARNING**

THE PUMP MUST BE WASHED BEFORE USING IT FOR THE FIRST TIME, IF IT IS NOT USED FOR A LONG TIME AND AFTER ANY COLOUR CHANGE.

7.5**STARTING**

Before beginning working, start the pump by following the instructions below:

1. Connect ground wire set to ground.
2. For all models with suction pipe, dip it into the product tank to be pumped.
For the model with hopper, fill it with the product to be pumped.
For the models on tank, fill the product tank to be pumped.
3. Open the two-way valve for paint recirculation (Ref. B on page 21).
4. Lift and turn gradually the pressure reducer knob (Ref. C on page 21).
Adjust it at a pressure slightly higher than 2.0 bar, to enable the pump to release the air.
5. Close the two-way valve for paint recirculation (Ref. B on page 21) and release the air through the gun, too.
6. Increase the pressure of the reducer connected to the pump
(Recommended pressure about 5.0 bar).
7. Adjust the paint pressure regulator as required (from 0 to 3.0 bar).
8. Adjust the spraying air by means of the reducer (Ref. D on page 21) and test the gun on a panel before using it.

PRECAUTIONS

- a) Use the gun under pressure.
- b) When the paint level inside the tank decreases, the pump can suck some air.
Increase the paint level.
- c) Do not drag the pump by pulling it by the pipes.

PRECAUTIONS: EMERGENCY STOP

When the pump must be stopped because of the following reasons:

- a) The material does not stop coming out from the gun.
- b) Fluid discharge through the connectors or the damaged pipe.
CLOSE THE EXHAUST BALL VALVE

7.6**DAILY INTERRUPTIONS**

1. When the pump is stopped:
 - The air supply must not be disconnected if the interruption is short.
 - If the interruption is long, turn the exhaust ball valve (A) discharge the air from the circuit and open the recirculation valve (B), to release the residual fluid pressure.
2. When the pump is stopped at the end of the working day:
 - Wash the fluid passages.
 - Remove the dip tube filter and the filter inside the paint filter and clean it.

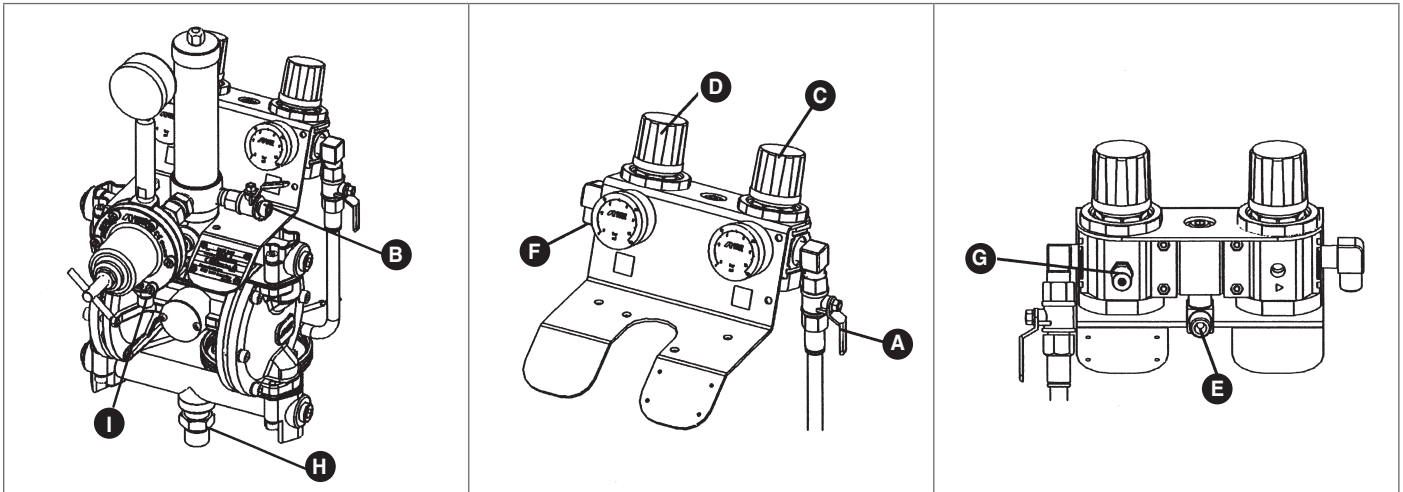

- A) Exhaust Ball valve
- B) Two-way valve for paint recirculation
- C) Pump air pressure reducer
- D) Gun air pressure reducer
- E) Feeder line connection
- F) Air connection to gun
- G) Safety valve
- H) Paint inlet joint
- I) Paint pressure regulator

Dust proof cap (female) : B) , E) , F) , H) , I)

Tank mount model : H) is not included (Dust proof cap male)

7.7 WRONG AND DANGEROUS USES

A wrong earthing, an insufficient ventilation, a naked flame or a spark can cause a fire or an explosion and provoke some serious injuries.



WARNING

IF SOME SPARKS OR AN ELECTRIC DISCHARGE WERE PERCEIVED, INTERRUPT IMMEDIATELY ALL PAINTING OPERATIONS.
DO NOT USE THE SYSTEM UNTIL THE PROBLEM CAUSE IS IDENTIFIED.

Keep away from the working area all kinds of waste, of solvent container, of solvent or petrol soaked rags or clothes.

Before starting the system disconnect all the electrical connections inside the working area.

Before using the system switch off all the naked flames and pilot lights inside the working area.

Do not smoke inside the working area.

During painting operations, or if there are some vapours in the air, do not switch on or off the lights inside the working area.

Do not use any petrol engine inside the working area.

Some organic solvents or discharged toxic vapours can enter the eyes or the skin, be swallowed or inhaled, by provoking serious injuries.

When the air engine is running, keep the face away from the exhaust.

7.8 PRESSURE RELEASE PROCESS

WARNING



1. Close the air to the gun.
 2. Close the air to the pump (exhaust ball valve).
 3. Make sure the recirculation pipe is not clogged. Then open gradually the recirculation two-way valve and leave it open.
 4. Hold the gun tightly and lean it on the earthed metal container, pull the trigger to release the pressure. If an automatic gun is used, supply the rod opening control with some air under pressure.
-

PRECAUTIONS



1. To operate the pump, use some filtered air by means of an air filter with filtering section lower than 50 μm . We recommend using a filter with condensate automatic discharge.
2. Do not make the pump idle.
3. Do not spray any paint or solvent towards the pump.
4. Do not install the pump near heat sources or in the sun. Put it far from sprinklings of water.
5. To avoid any problem after using bi-component paints, wash the pump immediately after using it otherwise all fluid passages could be clogged and the whole installation will have to be disassembled.

8.1 GENERAL NOTES



A suitable maintenance is important for a longer duration of the equipment in good working conditions and efficiency ensuring functional safety as time goes by.

All maintenance operations must be carried out by a qualified staff. The pump design and the materials used to manufacture it limit the maintenance interventions to a simple periodic cleaning.

The staff must be provided with the individual protections that are generally used for similar operations. They also must follow the safety rules described in section 8.2.

8.2 SAFETY RULES DURING MAINTENANCE

The main rules to follow during maintenance interventions on the unit are:

1. Disconnect the pneumatic supply before replacing any component.
2. Do not wear rings, watches, chains, bracelets, etc. during maintenance operations.
3. Always use the individual protections (gloves, safety shoes, etc.).
4. Do not use naked flames, points or pins for cleaning.
5. Do not smoke.

8.3 RECOMMENDED SCHEDULED OPERATIONS

Every 50 hours
working hours

Disassemble and clean the delivery and suction filters as well as the fluid passage ducts.

Note: If highly pigmented paints or paints with many particles tending to deposit are used, carry out maintenance operations at shorter intervals.

Every 2.000
working hours

Overhaul the whole painting unit and replace the worn components.

Note: The component corrosion speed varies according to the type of paint and the working conditions. To replace the worn components, follow the given instructions.

8.4 DIAPHRAGM PUMP DISASSEMBLY FROM ITS BASE SUPPORT

PRECAUTIONS

Before disassembling the pump, follow carefully the instructions below:

- a) While disassembling the pump, avoid damaging the O'rings.
 - b) To disassemble and reassemble the adaptors (5-3 pag.28) and the pump lids (2 pag.28) use a 5 mm Allen wrench and a 10 mm spanner.
 - c) Disassemble, in this order, the lower adaptor (5 pag.28), the upper adaptor (3 pag.28), the side lids (2 pag.28) by unscrewing the socket head screw by means of the suitable spanners.
1. Refer to the PRECAUTIONS FOR THE OPERATOR about the pressure release process (section 7.8).
 2. Disconnect the pump from the compressed air supply.
 3. Disassemble the suction filter system from the pump.
 4. Remove the recirculation pipe.
 5. Disassemble the paint regulator from the pump.
 6. Disassemble the pump casing from the support base by removing the four special screws.
 7. Remove the lower adaptor, the upper adaptor and the lid by following this order.

PRECAUTIONS

Some paint residues could remain inside the regulator: discharge them into the paint tank by overturning the pressure regulator itself.

8.5 LID AND CONNECTOR AND AIR OPERATING VALVE DISASSEMBLY

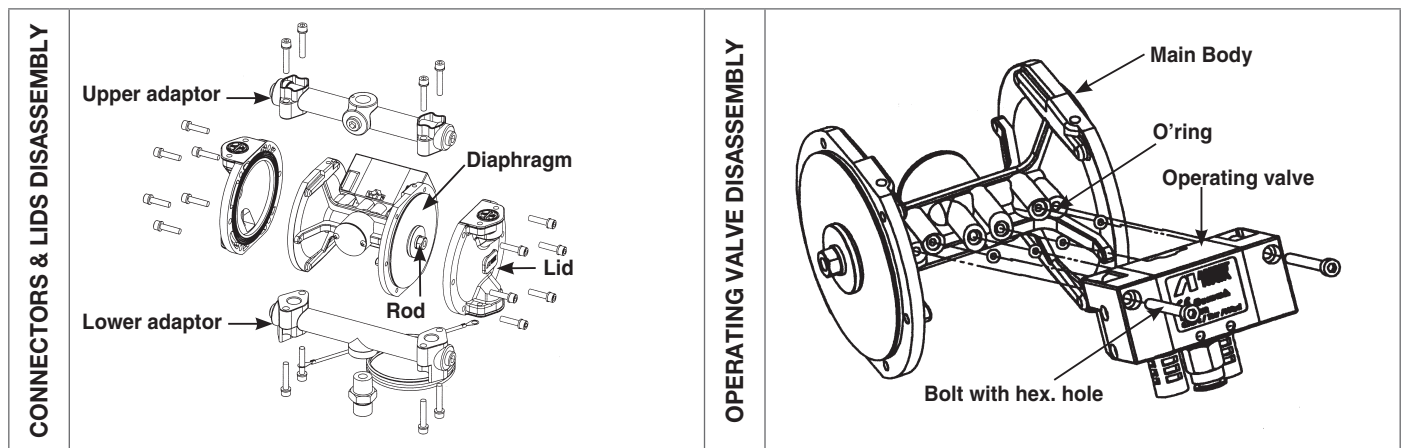

8.6 DIAPHRAGM SET DISASSEMBLY

A	Remove the 2 nuts with a 13mm spanner.	
B	Remove the following parts from rod: <ul style="list-style-type: none"> - Nut - Spring washer - Diaphragm holder (out) - O'ring - Diaphragm holder set (in/out) - Diaphragm holder (in) 	
		<p>D Hold flat face of center of the rod with a 12 mm spanner, and loosen the nut with a 13mm spanner on the side where the diaphragm has not been removed yet and disassemble as described in point B).</p>
C	Disassemble the rod by pressing on the screw and by pulling from the opposite side-towards the outside.	<p>E Remove the O'rings and the "Y" packings.</p>
		<h2>8.7 DIAPHRAGM SET REASSEMBLY</h2> <p>F To reassemble reverse the disassembly procedure</p>



PRECAUTIONS

Pay attention to the assembly direction of the “Y” packings (see the picture).

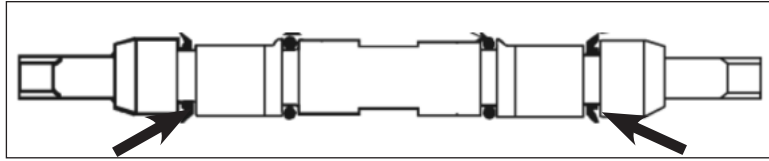

- A. Place the “Y” packings to the direction that they open outward.
- B. Lubricate the “Y” packing, the O’ring and the slots with some lithium grease.
- C. Tightening pressure of nuts : 8.83 Nm

8.8 INTAKE AND EXHAUST VALVE DISASSEMBLY

1. Press down the ball with a screw driver by using stopper of the lid to remove the intake valve and the ball.
2. Remove the O’ring. Do not use any metal tool to avoid scratching the pump.
3. Remove the ball on the exhaust valve and pull the exhaust valve up with finger.
4. Remove the O’ring. Do not use any metal tool to avoid scratching the pump.

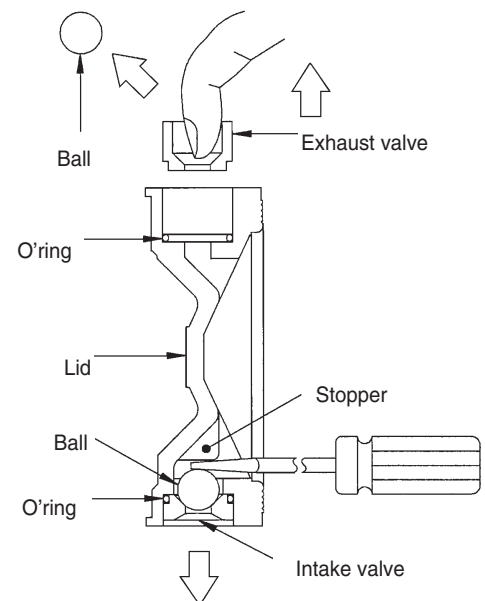

8.9 INTAKE AND EXHAUST VALVE REASSEMBLY

- A. **INTAKE VALVE**
 - Assemble the O ring on the valve.
 - Insert the ball
 - Insert the valve into its seat.
- B. **EXHAUST VALVE**
 - Assemble the O ring on the valve.
 - Insert the valve into its seat.
 - Insert the ball.



PRECAUTIONS

During the reassembly of the lids on main body, do not reverse the delivery side with the suction one.

9.1 TECHNICAL SPECIFICATIONS: PR-5BL - PR-5BL WB - PR-5BLN

VERSION	PR-5BL	PR-5BL WB	PR-5BLN
Paint passages material	Aluminium	Anodized Aluminium	Stainless Steel
Weight	850g	850g	1020g
Max. primary pressure	7.0 bar		
Max. flow	1.5 l/min.		
Pressure range	3.0 bar		
Fluid inlet joint	G 3/8"		
Fluid outlet joint	G 3/8"		

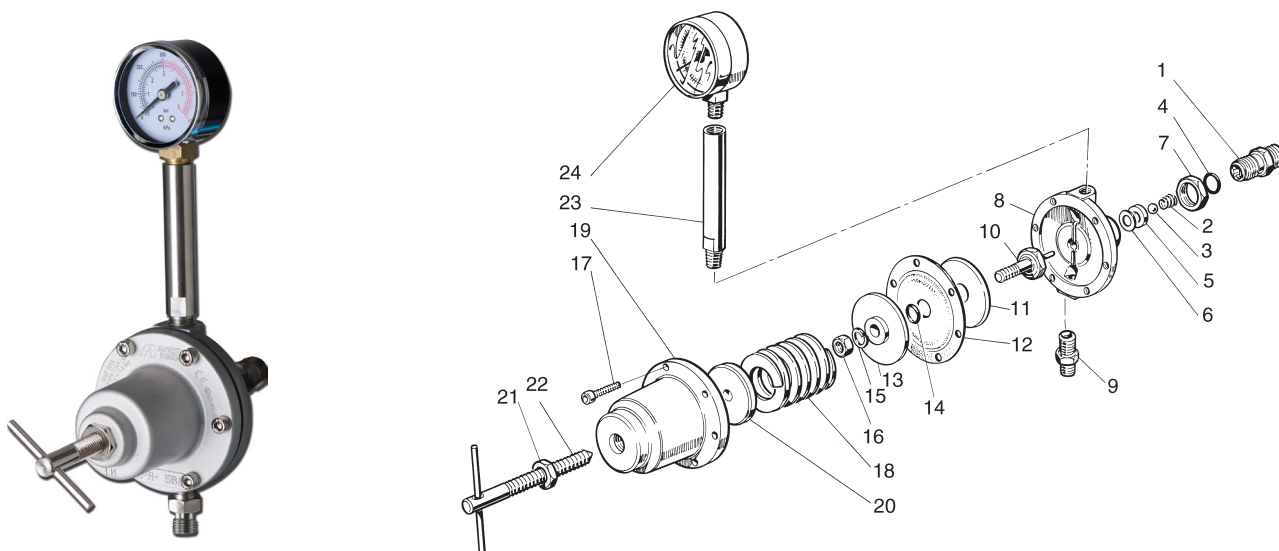

9.2 PAINT REGULATOR MAINTENANCE, DISASSEMBLY AND ASSEMBLY

IMPORTANT



When you disassemble main body, rising pipe and pressure gauge, apply sealing agent to each threaded section to keep airtightness.

Whenever disassembling ball and seat of tungsten carbide, you have to be sure to confirm that there is no wear or damage. If there is any wear or damage, replace with new one.

9.3 DISASSEMBLING (Reference: Section 10.3 - pag.30)

1. Fully loosen handle set (ref.22), and remove bolt with hex. hole (ref.17), diaphragm cap (ref.19), spring stopper (ref.20), adjusting spring (ref.18) and diaphragm.
2. Loosen jam nut (ref.7), and remove joint (ref.1), valve spring (ref.2), ball (ref.3), seat (ref.5) and packing (ref.6).
3. Fix hex. section of diaphragm bolt (ref.10), and remove hex. nut (ref.16), spring washer (ref.15), diaphragm stopper (ref.13), O ring (ref.14), diaphragm (ref.12) and diaphragm holder (ref.11).
4. If O ring placed into joint is damaged or deformed, remove O ring from joint.

9.4 ASSEMBLY (Reference: Section 10.3 - pag.30)

1. Check on each section if there are damage and foreign matter .
2. Fit diaphragm holder (ref.11), diaphragm (ref.12), O ring (ref.14), diaphragm holder (ref.13) and spring washer (ref.15) into diaphragm bolt (ref.10) and tighten hex. nut (ref.16). Tightening torque of hex. nut 9.8N-m
3. Mount diaphragm section, adjusting spring (ref.18), spring stopper (ref.20), and diaphragm cap (ref.19) on main body (ref.8), and evenly tighten bolts with hex. bolt (ref.17) diagonally.
4. Fit O ring (ref.4) to joint (ref.1).
5. Fit packing (ref.6) and tungsten carbide seat (ref.5) to body (ref.8).
6. Fit valve spring (ref.2) and ball (ref.3) to joint (ref.1), and then fit joint (ref.1) to body (ref.8). Tightening torque of joint 14.7N-m
7. Fix joint (ref.1) with jam nut (ref.7).

IMPORTANT



Fit tungsten carbide seat to main body so that tungsten carbide ball can be fitted on tapered side. Do not forget to fit packing.

Wrong assembling can cause wrong movement of pointer of pressure gauge due to leakage from seat, failing performance.



Pay attention to tightening torque when fitting joint (ref.1).

Too much tightening can damage main body.

Tightening torque of joint 14.7 N-m

When fitting joint, pay attention that tungsten carbide ball does not slip out of the seat.

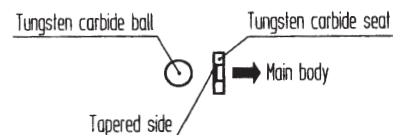

9.5 SET UP OF 2-WAY JOINT CONNECTION KIT (OPTIONAL)

For simultaneous use of 2 spray guns, available in 2 different versions. (Aluminium & Stainless Steel)

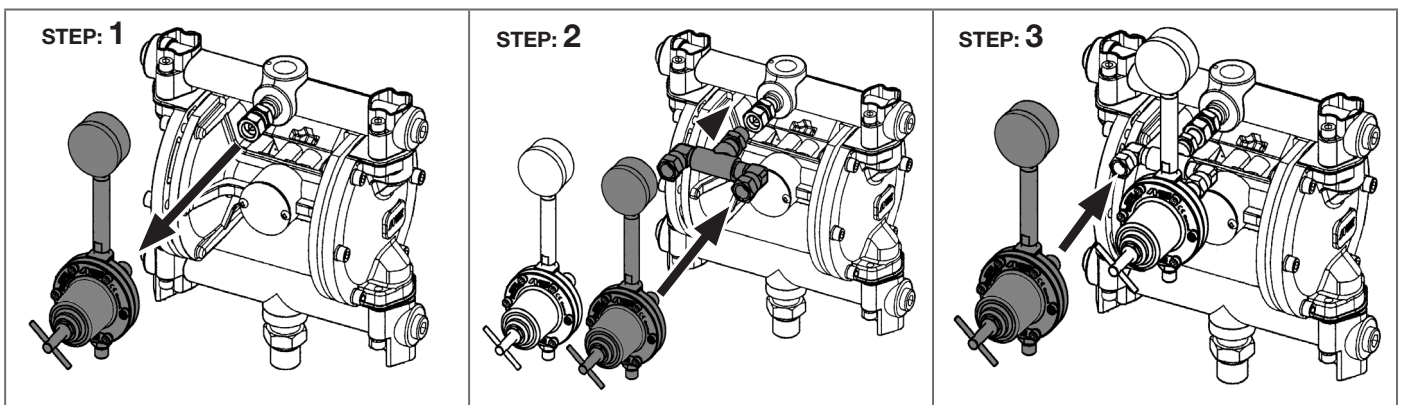

9.6 PAINT FILTER MAINTENANCE

If the pump is used correctly (that is it is washed carefully each time it is used), the paint filter needs no special maintenance, with the exception of cleaning and filter replacement.

10.1 DPS DIAPHRAGM PUMP SET

Ref.	Description	Qty
A	PAINT REGULATOR SET	1
B	AIR REGULATOR SET	1
C	PAINT FILTER SET	1
E	SWIVEL JOINT	1
F	HEX. SOCKET BOLT WITH WASHER	2
G	CONNECTING BOLT	2
I	NIPPLE	1
M	BALL VALVE	1
N	JOINT *	1
O	PIPE	1
P	WASHER BOLT	2+2

*1: for Stainless Steel & Anodized Aluminium

10.2 DDP MAIN BODY SPARE PARTS LIST

Ref.	Description	NOTE	DDP 90 F	DDP 120 B
1	MAIN BODY	•	1	1
2	LID	•	2	2
3	UPPER ADAPTOR	•	1	1
4	HEXAGON SOCKET PLUG		4	4
5	LOWER ADAPTOR	•	1	1
6	PACKING SET	#	4	4
7	EXHAUST VALVE	#	2	2
8	O'RING SET		4	4
9	STEEL BALL SET	#	4	4
10	GROUND WIRE		1	1
11	INTAKE VALVE	#	2	2
12	HEX. SOCKET BOLT WITH WASHER		12	12
13	HEX. SOCKET BOLT WITH WASHER		8	8
14	AIR OPERATING VALVE SET		1	1
15	HEX. NUT		2	2
16	SPRING WASHER		2	2
17	DIAPHRAGM HOLDER(OUTER)		2	2
18	DIAPHRAGM HOLDER(INNER)	#	2	2
19	DIAPHRAGM SET (2 IN+2 OUT)	#	2	2
21	Y PACKING	#	2	2
22	O'RING	#	2	2
23	O'RING	#	2	2
24	O'RING	#	4	4
25	ROD		1	1
27	MUFFLER		2	2
28	BLANKING COVER		1	1
29	TAPPING SCREW		2	2
30	ELBOW UNION		1	1
31	JOINT	•	1	1
32	PIN		-	1

Parts subjects to wear: #

• Marked parts differt among: Aluminium, Stainless Steel, Anodized Aluminium.

MAIN BODY DDP

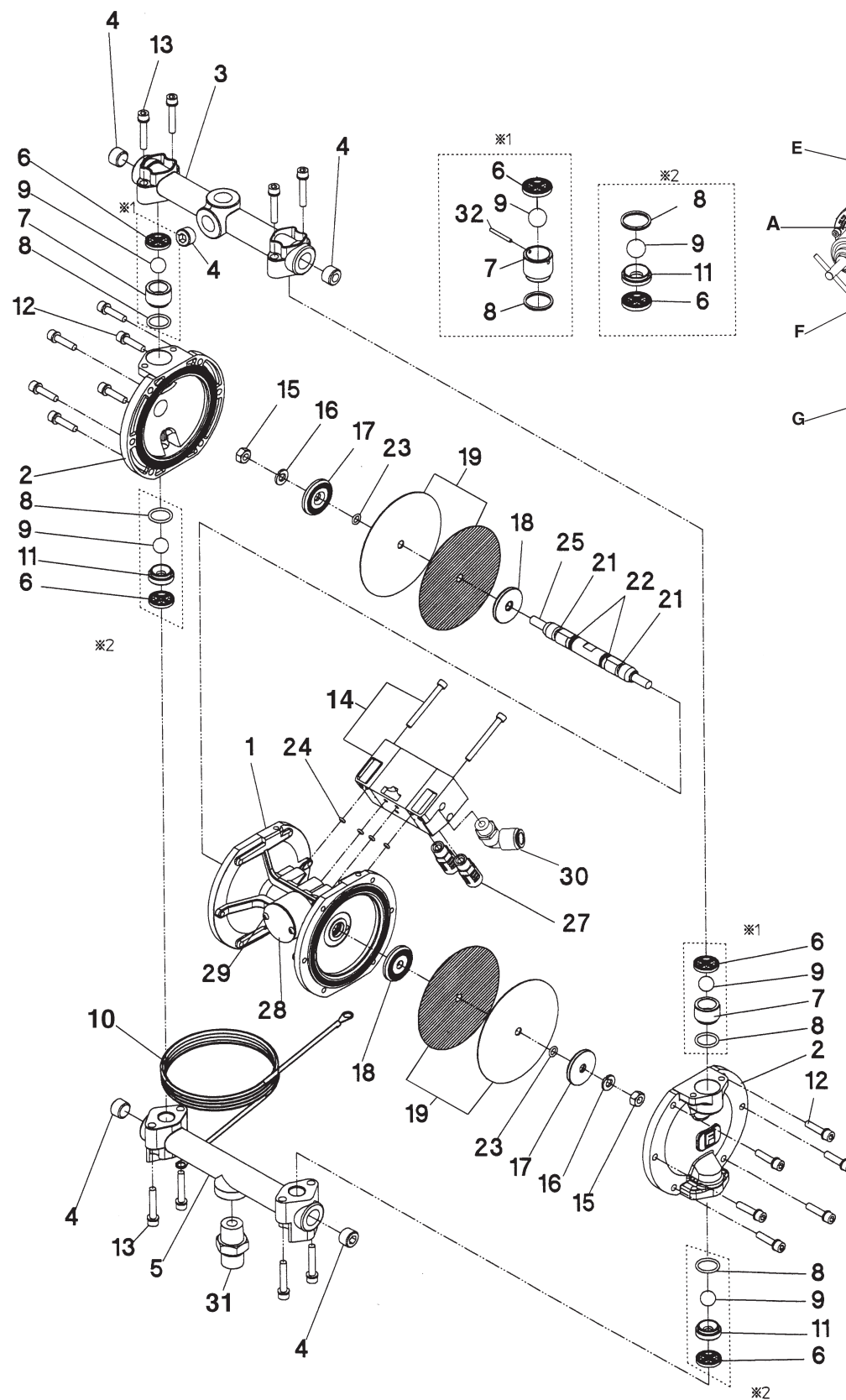

DPS PUMP SET

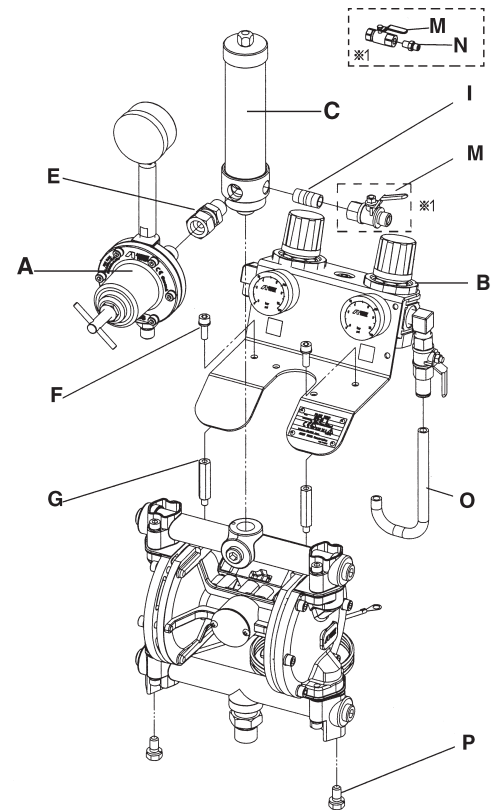

10.3 PAINT PRESSURE REGULATOR - A) PR-5BL | PR-5BL WB | PR-5BLN

Ref.	Description	
1	JOINT G3/8"	
2	VALVE SPRING	
3	CARBIDE BALL	#
4	O'RING	
5	CARBIDE SEAT	#
6	PACKING	
7	HEX. NUT	
8	BODY	•
9	JOINT G1/4"-G3/8"	
10	DIAPHRAGM BOLT	
11	DIAPHRAGM HOLDER	
12	DIAPHRAGM	#
13	DIAPHRAGM STOPPER	
14	O'RING	#
15	SPRING WASHER	
16	HEXAGON NUT	
17	HEX. SOCKET BOLT	
18	ADJUSTING SPRING	
19	DIAPHRAGM CAP	
20	SPRING STOPPER	
21	HEXAGON NUT	
22	HANDLE SET	
23	RISING PIPE	
24	PRESSURE GAUGE	

10.4 2-WAY JOINT CONNECTION KIT - OPTIONAL

Ref.	Description	Qty.		
for ALUMINIUM TYPE			ALUMINIUM TYPE 	ALL TYPES
1	PAINT REGULATOR	1		
2	JOINT	1		
3	T-JOINT	1		
4	ELBOW UNION	2		
for STAINLESS STEEL TYPE			STAINLESS STEEL TYPE 	ALL TYPES
1	PAINT REGULATOR	1		
2	JOINT	1		
3	T-JOINT	1		
5	STREET UNION	2		
6	UNION JOINT M-F	2		
for ALL TYPES				
7	SUB PLATE	1		
8	BOLT WITH HEX. HOLE	4		
9	PLATE	1		
10	PRESSURE GAUGE	1		
11	ELBOW UNION	2		
12	TUBE	1		
14	AIR REGULATOR	1		
15	ELBOW	2		
16	T-JOINT	1		
17	UNION JOINT M-F	1		

10.5 AIR REGULATOR SET - B)

Ref.	Description	Qty.	
1	PANEL	1	
2	AIR REGULATOR SET (2 REGULATORS SET)	1	
	AIR REGULATOR (SINGLE)	1	
3	PRESSURE GAUGE	1	
4	ELBOW R1/4" G1/4"	1	
5	ELBOW R1/4" R1/4"	1	
6	BALL VALVE RC1/4" R1/4"	1	
7	FEMALE UNION Ø10 x RC1/4"	1	
8	SAFETY VALVE	1	

10.6 PAINT FILTER SET - C)

Ref.	Description	Qty.	
1	BODY	1	
2	FILTER BOLT	1	
3	CYLINDER	1	
4	CYLINDER CAP	1	
5	PACKING	1	
6	PACKING	1	
7	JOINT	1	
8	BOLT CAP	1	
9	SPRING PIN	1	
10	FILTER (100 MESH)	1	

10.7 ACCESSORIES

Ref.	CART SET	Qty.	CART SET	STAND SET
1	AXLE	1		
2	"U" BOLT WITH HEX. NUT	2 + 4		
3	SNAP PIN	4		
4	WASHER	4		
5	SOLID TIRE	2		
6	HANDLE	1		
7	HEXAGON NUT (M8)	1		
8	BOLT WITH HEX. HOLE (M8)	1		
9	HEXAGON NUT (M6)	1		
10	BOLT WITH HEX. HOLE (M6)	1		
			LID SET	WALL MOUNTING BRACKET

10.8 SUCTION HOSE, DIP TUBE WITH FILTER & DRAIN HOSE

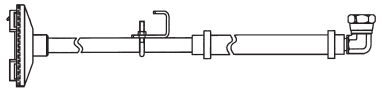
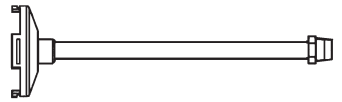
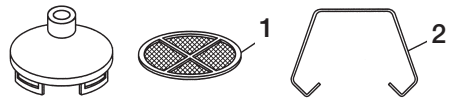
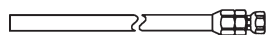
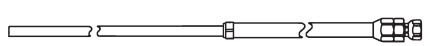
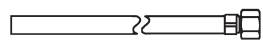
Ref.	Description	Qty.	
SUCTION HOSE SET for CART TYPE - STAND TYPE - WALL BRACKET TYPE			
PIC. 1	SUCTION HOSE SET	1	
SUCTION PIPE SET for TANK TYPE			
PIC. 2	SUCTION PIPE SET	1	
SUCTION FILTER SET for ALL TYPES			
PIC. 3	SUTION FILTER SET	1	
1	FILTER (50 mesh)		
2	FILTER STOPPER		
DRAIN HOSE SET for CART TYPE - STAND TYPE - WALL BRACKET TYPE			
PIC. 4	DRAIN HOSE SET	1	
DRAIN HOSE SET for TANK TYPE			
PIC. 5	DRAIN HOSE SET	1	
DRAIN HOSE SET for HOPPER TYPE			
PIC. 6	DRAIN HOSE SET	1	

11.1 DIAPHRAGM PUMP - TROUBLESHOOTING



IMPORTANT

Spare parts marked by [#] must be ANEST IWATA original items. If not, it can cause failure.

PROBLEM	CAUSE	SOLUTION	
PUMP DOES NOT WORK, IT STOPS OR DOES NOT RESTART	The compressed air does not reach the pump air inlet.	Connect the compressed air.	
	The air pressure is too low to start the pump.	Set air pressure of at least 2 bar.	
	The exhaust valve (A pg. 21) is in discharging position.	Turn the valve in the right position.	
	The air regulator is closed.	Open the air regulator.	
	The paint regulator is closed.	Open the paint regulator.	
	The silencer (27 pg. 28) is clogged.	Replace the silencer.	
	The following parts are clogged due to solidified paint inside them.		
	The filter inside the paint filter (ref. 10 pg. 31 - pp.10.6).	Clean and replace the fluid filter.	
	Every pump fluid passage.	Remove the clogging material.	
	Every paint regulator fluid passage.	Remove the clogging material.	
	The pump does not run.	Disassemble the pump and check the following parts which will be replaced if damaged:	
		PTFE diaphragm [#]	
		Rubber diaphragm [#]	
“Y” packings (21 pg. 28) [#]			
O ring. [#]			
Rod (any strange deformation, scratches or burrs). [#]			
Self-lubricating bushings. [#]			
Main casing inside diameters (Ø 15) damaged (scratched or with burrs).			
Replace Air Operating Valve (14 pg. 28)			
PUMP WORKS BUT THE PAINT DOES NOT COME OUT	The following parts are unscrewed or damaged.		
	The pump suction connector with the suction pipe	Check if some tightening are loosened and tighten them.	
	The suction connector	Put some adhesive and tighten.	
	The lower adaptor	Tighten.	
	The dip tube suction pipe	If the suction pipe is damaged (it sucks air), replace it.	

PROBLEM	CAUSE	SOLUTION
PUMP WORKS BUT THE PAINT DOES NOT COME OUT	The pressure regulator, the recirculation two-way valve and the gun are closed?	Open the pressure regulator and then the gun and the recirculation two-way valve
	The following parts are clogged with some solidified paint residues?	
	The filter inside the paint filter (ref.10 pg. 31 - pp.10.6).	Clean and replace the filter.
	The suction filter.	Clean and replace the filter.
	The suction hose set.	Remove the solidified part.
	All the pump fluid passages.	Remove the solidified part.
	All the paint regulator fluid passages.	Remove the solidified part. [#]
	The upper and lower balls are stuck?	Clean the surfaces and release them. [#]
	The following parts are damaged or worn.	
	The ball seats (exhaust and intake valves).	Replace them. [#]
	The balls.	Replace them. [#]
	The O'rings of each ball seat	Replace them. [#]
The PTFE diaphragms	Replace them. [#]	
PAINT OUTPUT CONTAINS AIR	The following parts are unscrewed or damaged?	
	The pump suction joint (ref. 31 page 28) with suction pump.	Check the loosened tightening and tighten them.
	The suction joint (ref. 31 page 28).	Put some adhesive and tighten.
	The lower adaptor.	Tighten.
	The suction pipe of dip tube.	If the dip tube set is damaged (it sucks some air), it must be replaced.
	The nuts at the rod ends are loosened?	Tighten them. [#]
	The following parts are damaged?	
	Diaphragms.	Replace them. [#]
	The O rings (ref. 23 page 28) between the PTFE diaphragm and the diaphragm seat.	Replace them. [#]
PAINT OUTPUT DECREASES	The paint regulator is closed?	Open the paint regulator.
	Check air sources.	
	The air flow is interrupted by the air pipe bending.	Restore the air pipe
	The air pressure is too low to start the pump.	Set air pressure of at least 2 bar.
	The air regulator is closed.	Open the air regulator.
	The silencer (ref. 27 page 28) is clogged.	Replace it.

PROBLEM	CAUSE	SOLUTION
PAINT OUTPUT DECREASES	The following parts are clogged with some solidified paint?	
	The filter inside the paint filter.	Clean and replace the filter.
	The suction filter (of the dip tube).	Clean and replace the filter.
	The suction pipe (of the dip tube).	Remove the solidified part.
	All the pump material passages.	Remove the solidified part.
	All the paint regulator material passages.	Remove the solidified part.
	The following parts are damaged or worn?	
	The ball seats.	Replace them.
	The balls (ref. 9 pag.28)	Replace them.
	The PTFE diaphragms.	Replace them.

11.2 PAINT PRESSURE REGULATOR (Reference: Section 10.3 - pag.30)

PROBLEM	CAUSE	SOLUTION
THE POINTER OF PRESSURE GAUGE OVERTAKES MAX. PRESSURE	Not properly seated or deposits by foreign matter	Clean and assemble again.
	Wear or damage on seat	Replace tungsten carbide seat (ref. 5) [#]
	Wear and damage on ball	Replace tungsten carbide ball (ref. 3) [#]
	Seat packing (ref. 6) damaged	Replace packing (ref. 6) [#]
PAINT LEAKS OUTSIDE	Loose joint (ref. 1)	Tighten
	Loose bolt with hex. Hole (ref. 17)	Tighten
	Loose hex. nut (ref. 16)	Tighten
	Diaphragm damaged (ref. 12)	Replace diaphragm [#]
	O ring damaged (ref. 4)	Replace O ring [#]
SECONDARY PRESSURE DOES NOT RISE	Primary pressure is too low	Raise primary side pressure
	Failure of pressure gauge (ref. 24)	Replace pressure gauge
	Paint hardened in rising pipe (ref. 23)	Clean paint out
PRESSURE IS UNSTABLE	Damage to valve spring (ref. 2)	Replace valve spring (ref. 2) [#]

12. EQUIPMENT STORAGE

If the diaphragm pump is to be stored for a certain period, the following operations are recommended:

- Disconnect the equipment from the energy sources.
- Remove all residues and deposits from the pump.
- Cover the equipment with a waterproof tarpaulin.

12.1 DISMANTLING

If for any reason the pump is to be dismantled, some important rules have to be followed to safeguard the environment.

All sheaths, flexible ducts and plastic or non metal components will have to be disposed of separately.





EUROPE:

ANEST IWATA Italia S.r.l.

Torino - ITALY
info@anest-iwata.it
www.anest-iwata.it

ANEST IWATA Deutschland GmbH

Leipzig - GERMANY
info@anest-iwata.de
www.anest-iwata.de

ANEST IWATA France S.A.

Saint Quentin Fallavier, Lyon - FRANCE
info@anest-iwata.fr
www.anest-iwata.fr

ANEST IWATA U.K. Ltd.

St. Neots Cambridgeshire - ENGLAND
enquiries@anest-iwata.co.uk
www.anest-iwata.co.uk

ANEST IWATA Iberica S.L.

Badalona - Barcelona - SPAIN
info@anest-iwata.es
www.anest-iwata.es

ANEST IWATA Scandinavia AB.

Partille, Göteborg - SWEDEN
info@anest-iwata.se
www.anest-iwata.se

ANEST IWATA Polska Sp. Z o.o.

Poznań - POLAND
info@anestiwata.com.pl
www.anest-iwata.pl

NORTH AMERICA:

ANEST IWATA USA Inc.

West Chester - Ohio - U.S.A.
inquiry@anestiwata.com
www.anestiwata.com

SOUTH AMERICA:

ANEST IWATA DO BRASIL COMERCIAL Ltda.

Sao Paulo - BRAZIL
contato@anest-iwata.net.br
www.anest-iwata.net.br

AUSTRALIA:

ANEST IWATA Australia Pty Ltd.

Sidney - AUSTRALIA
info@anest-iwata.com.au
www.anest-iwata.com.au

AFRICA:

ANEST IWATA South Africa Pty Ltd.

Johannesburg - REPUBLIC OF SOUTH AFRICA
www.anest-iwata.co.za

ASIA:

ANEST IWATA Coating Solutions Corporation

Yokohama - JAPAN
www.anest-iwataeu.co.jp

ANEST IWATA Middle East FZE

Dubai - UNITED ARAB EMIRATES
info@anest-iwata-me.com
www.anest-iwataeu.com

ANEST IWATA Motherson Coating Equipment Ltd.

Noida - INDIA
sales@aim.motherson.com
www.motherson.com/anest-iwata-motherson.html

ANEST IWATA Russia LLC

Moscow - RUSSIA
tam@anestiwata.ru
www.anestiwata.ru

ANEST IWATA Shanghai Corporation

Shanghai - CHINA
customer@anest-iwata-sh.com
www.anest-iwata-sh.com

ANEST IWATA Taiwan Corporation

Hu-Kuo - TAIWAN R.O.C.
service@anestiwata.com.tw
www.anestiwata.com.tw

ANEST IWATA Vietnam CO. Ltd.

Ho Chi Minh City - VIETNAM
info@anest-iwata.vn
www.anest-iwatasoutheastasia.com

PT. ANEST IWATA Indonesia

Jakarta - INDONESIA
www.anest-iwatasoutheastasia.com

ANEST IWATA Southeast Asia CO. Ltd.

Bangkok - THAILAND
info@anest-iwata.co.th
www.anest-iwatasoutheastasia.com



HEADQUARTERS: ANEST IWATA Corporation

Yokohama - JAPAN
www.anest-iwata.co.jp